

EXISTING FIRE SERVICE

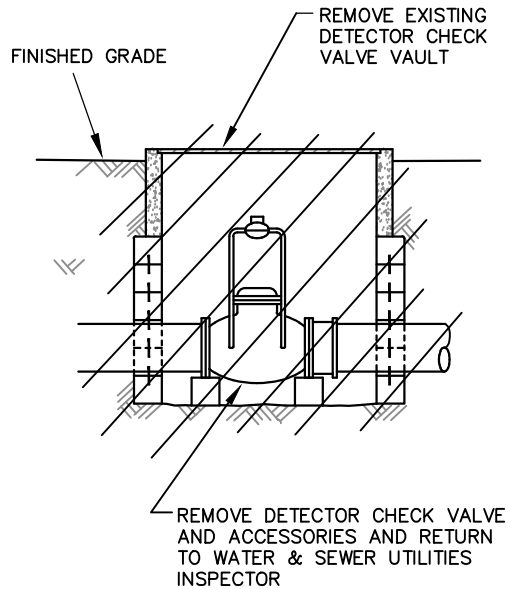

NEW FIRE SERVICE

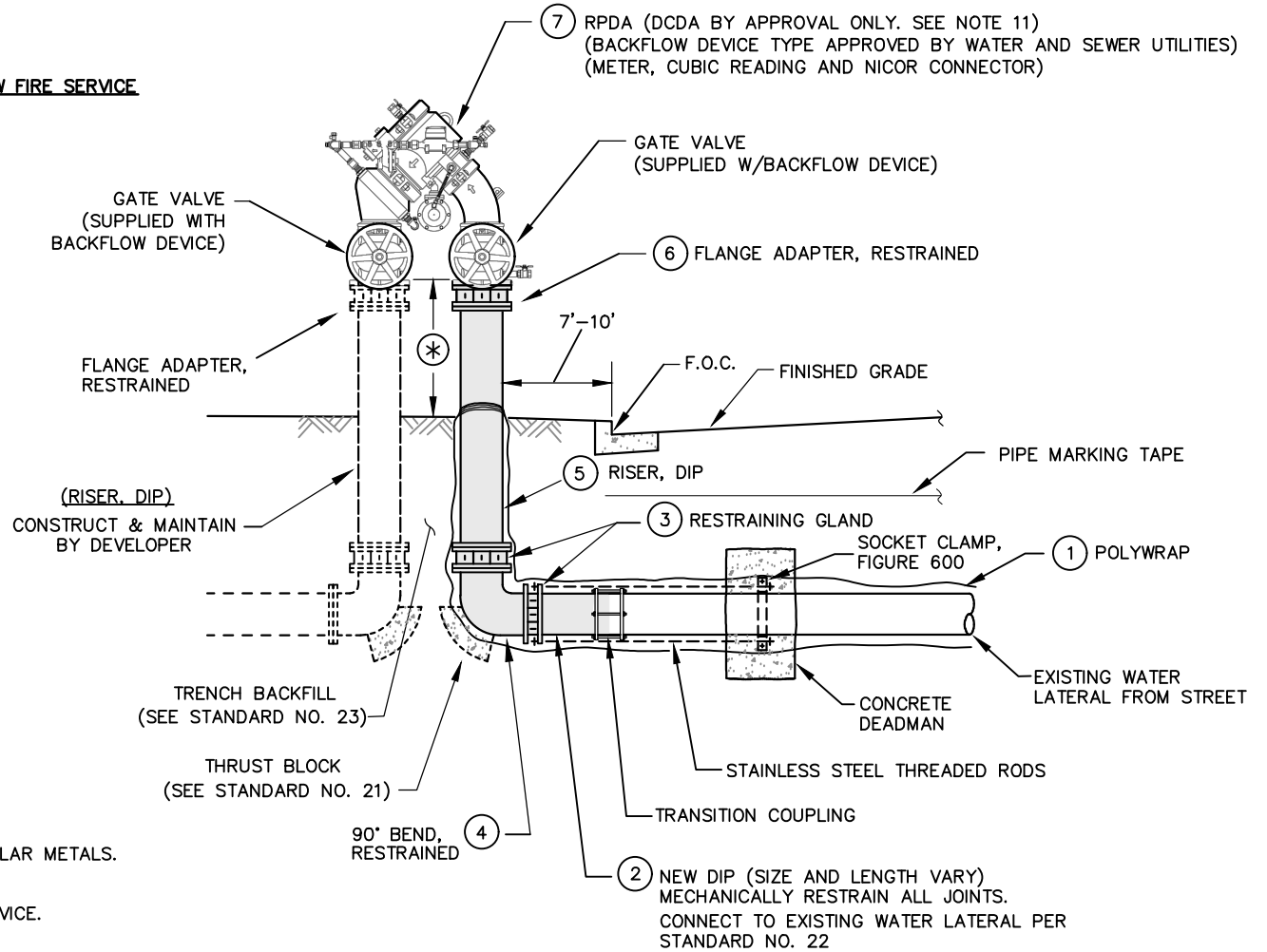

NOTES:

1. ADD DIELECTRIC UNION WHEN TRANSITIONING BETWEEN DISSIMILAR METALS.
2. KEEP METER & BACKFLOW INSTALLATION PLUMB AND LEVEL.
3. NO ADDITIONAL SERVICE CONNECTIONS ALLOWED ON FIRE SERVICE.
4. MECHANICALLY RESTRAIN ALL JOINTS.
5. PROVIDE 5 FEET CLEARANCE AROUND SERVICE ABOVE-GROUND.
6. BOLLARDS MAY BE REQUIRED AS DETERMINED BY CITY.
7. WATER UTILITY EASEMENT IS REQUIRED 5 FEET AROUND ALL SIDES OF THE DEVICE.
8. UPGRADED BACKFLOW DEVICE SHALL NOT BLOCK VIEW OF PIV OR FDC, IT SHALL BE OFFSET 3 FEET.
9. ALL UPGRADES REQUIRED FIRE DEPARTMENT APPROVAL.
10. IF FIRE DEPARTMENT REQUIRES A TAMPER SWITCH, APPLICANT SHALL SIGN A HOLD HARMLESS AGREEMENT WITH WATER AND SEWER UTILITIES PRIOR TO INSTALLATION.
11. DCDA ASSEMBLY ALLOWED ONLY WITH APPROVAL OF THE WATER AND SEWER UTILITIES DIRECTOR.

- (*) 14" TO 18" FOR MODEL:
 WILKINS 450DA (DCDA)
 WILKINS 375DA, 475DA (RPDA)
 FEBCO LF876V (DCDA)
 18" TO 24" FOR MODEL:
 WATTS LF909 (RPDA)



Drawn By: DUC L. / MITCHELL S.
 Checked By: AHMED A. / JAMES M.
 Approved By: SHILPA M.
 Revised Date: 2/1/2023

Signature:

 Director of
 Water and Sewer Utilities

CITY OF SANTA CLARA
 WATER AND SEWER UTILITIES - STANDARD NO. 31
**UPGRADE EXISTING 4" - 10" FIRE SERVICE ASSEMBLY
 (WITH ABOVE-GRADE BACKFLOW DETECTION ASSEMBLY)**

Standard No. 31 – Upgrade Existing 4"-10" Fire Service Assembly (with Above Grade Backflow Detection Assembly) – Material List

Domestic Products Only.

Use 316 stainless steel bolts, flange gasket with EPDM rubber, nuts, and washers for all bolted connections.

Coat above ground fire service shall be painted fire safety red.

Provide 5-foot clearance around service above ground from all structures, objects, landscaping, etc.

Material	Description	Manufacturer	Model
1. Polywrap	Blue. 8 mil low density or 4 mil high density polyethylene film installed per AWWA C105. Tape ends to pipe with 10 mil tape.		
2. Pipe	Mechanically restrain all joints. -Ductile iron, cement lined and zinc coated, Class PC350 or greater. Protect with polywrap for underground pipe.	US Pipe McWane Ductile	
3. Restraining Gland	Joint restraint for use with mechanical joint fittings. Size as specified.	US Pipe (not allowed above ground)	MJ Field Lok
		EBAA	Megalug Series 1100
		KRAUSZ	Hymax Grip
4. 90 Degree Bend, restrained	AWWA C-153 ductile iron with mechanical joint, cement lined and zinc coated with stainless steel bolts and gaskets	Tyler Union	with Megalug Restraining gland
	AWWA C-219, ductile iron, mechanically restrained, fusion bonded epoxy with stainless steel bolts	KRAUSZ	Hymax Grip
5. Riser	Ductile iron, cement lined and zinc coated, PC350 minimum.		
6. Flange Adapter, restrained	AWWA C-153 ductile iron, MJ x FLG	Tyler Union	with Megalug Restraining gland
	AWWA C-219, ductile iron, fusion bonded epoxy with stainless steel bolts	KRAUSZ	Hymax Grip
7. Double Check Detection Assembly	Includes gate valves and bypass (leak detection) Provide encoded meter register with Nicor connector. Register shall be compatible with Elster transmitter. All registers to be facing inlet and provide cubic feet reading.	Wilkins	450DA
		FEBCO	LF876V
Reduced Pressure Principle Backflow Detection Assembly	Includes gate valves and bypass (leak detection) Provide encoded meter register with Nicor connector. Register shall be compatible with Elster transmitter. All registers to be facing inlet and provide cubic feet reading. Each RP to have separate serial number.	Wilkins	375DA, 475DA,475STDA
*(Unit to be determined by City)			