

TRAFFIC DATA SERVICE

6280 San Ignacio Ave Suite C
San Jose, CA 95119

tdsbay@cs.com

File Name : 1 FINAL
Site Code : 00000001
Start Date : 9/17/2024
Page No : 1

Groups Printed- Vehicles

Start Time	LOS OLIVOS DR Southbound					SERRA AVE Westbound					LOS OLIVOS DR Northbound					Eastbound					Int. Total
	Right	Thru	Left	Peds	App. Total	Right	Thru	Left	Peds	App. Total	Right	Thru	Left	Peds	App. Total	Right	Thru	Left	Peds	App. Total	
12:00 AM	0	2	1	0	3	0	0	0	0	0	0	1	0	0	1	0	0	0	0	0	4
12:15 AM	0	0	0	0	0	0	0	0	0	0	0	0	0	0	0	0	0	0	0	0	0
12:30 AM	0	1	0	0	1	0	0	0	0	0	0	0	0	0	0	0	0	0	0	0	1
12:45 AM	0	1	0	0	1	1	0	0	0	1	0	0	0	0	0	0	0	0	0	0	2
Total	0	4	1	0	5	1	0	0	0	1	0	1	0	0	1	0	0	0	0	0	7
01:00 AM	0	0	0	0	0	0	0	0	0	0	0	0	0	0	0	0	0	0	0	0	0
01:15 AM	0	0	0	0	0	0	0	0	0	0	0	0	0	0	0	0	0	0	0	0	0
01:30 AM	0	0	0	0	0	0	0	0	0	0	0	0	0	0	0	0	0	0	0	0	0
01:45 AM	0	0	0	0	0	0	0	0	0	0	0	1	0	0	1	0	0	0	0	0	1
Total	0	0	0	0	0	0	0	0	0	0	0	1	0	0	1	0	0	0	0	0	1
02:00 AM	0	0	0	0	0	0	0	0	0	0	0	0	0	0	0	0	0	0	0	0	0
02:15 AM	0	0	0	0	0	0	0	0	0	0	0	0	0	0	0	0	0	0	0	0	0
02:30 AM	0	0	0	0	0	0	0	0	0	0	0	0	0	0	0	0	0	0	0	0	0
02:45 AM	0	0	0	0	0	0	0	0	0	0	0	1	0	0	1	0	0	0	0	0	1
Total	0	0	0	0	0	0	0	0	0	0	0	1	0	0	1	0	0	0	0	0	1
03:00 AM	0	0	0	0	0	0	0	0	0	0	0	1	0	0	1	0	0	0	0	0	1
03:15 AM	0	1	0	0	1	0	0	0	0	0	0	0	0	0	0	0	0	0	0	0	1
03:30 AM	0	1	0	0	1	0	0	0	0	0	0	0	0	0	0	0	0	0	0	0	1
03:45 AM	0	1	0	0	1	0	0	0	0	0	0	0	0	0	0	0	0	0	0	0	1
Total	0	3	0	0	3	0	0	0	0	0	0	1	0	0	1	0	0	0	0	0	4
04:00 AM	0	0	0	0	0	0	0	0	0	0	0	0	0	0	0	0	0	0	0	0	0
04:15 AM	0	0	0	0	0	0	0	0	0	0	0	0	0	0	0	0	0	0	0	0	0
04:30 AM	0	0	0	0	0	0	0	0	0	0	0	1	0	0	1	0	0	0	0	0	1
04:45 AM	0	0	0	0	0	0	0	0	0	0	1	0	0	0	1	0	0	0	0	0	1
Total	0	0	0	0	0	0	0	0	0	0	1	1	0	0	2	0	0	0	0	0	2
05:00 AM	0	0	0	0	0	1	0	0	0	1	1	0	0	0	1	0	0	0	0	0	2
05:15 AM	0	1	0	0	1	1	0	0	0	1	0	2	0	0	2	0	0	0	0	0	4
05:30 AM	0	1	0	0	1	3	0	0	0	3	1	1	0	0	2	0	0	0	0	0	6
05:45 AM	0	0	0	0	0	0	0	0	0	0	0	3	0	0	3	0	0	0	0	0	3
Total	0	2	0	0	2	5	0	0	0	5	2	6	0	0	8	0	0	0	0	0	15
06:00 AM	0	0	0	0	0	0	0	0	0	0	0	2	0	0	2	0	0	0	0	0	2
06:15 AM	0	1	2	0	3	0	0	0	1	1	0	2	0	0	2	0	0	0	0	0	6
06:30 AM	0	1	0	0	1	2	0	1	0	3	2	3	0	0	5	0	0	0	0	0	9
06:45 AM	0	0	2	0	2	4	0	0	2	6	1	0	0	0	1	0	0	0	0	0	9
Total	0	2	4	0	6	6	0	1	3	10	3	7	0	0	10	0	0	0	0	0	26
07:00 AM	0	3	2	0	5	0	0	0	2	2	0	0	0	0	0	0	0	0	0	0	7
07:15 AM	0	6	3	0	9	1	0	0	1	2	1	4	0	0	5	0	0	0	0	0	16
07:30 AM	0	8	1	1	10	2	0	0	1	3	2	7	0	1	10	0	0	0	0	0	23
07:45 AM	0	11	2	0	13	2	0	1	1	4	2	10	0	0	12	0	0	0	0	0	29
Total	0	28	8	1	37	5	0	1	5	11	5	21	0	1	27	0	0	0	0	0	75
08:00 AM	0	12	1	0	13	6	0	2	2	10	1	15	0	0	16	0	0	0	0	0	39
08:15 AM	0	8	2	0	10	5	0	3	1	9	0	11	0	0	11	0	0	0	0	0	30
08:30 AM	0	10	5	0	15	3	0	4	0	7	2	10	0	1	13	0	0	0	0	0	35
08:45 AM	0	8	4	0	12	2	0	0	3	5	1	7	0	1	9	0	0	0	0	0	26
Total	0	38	12	0	50	16	0	9	6	31	4	43	0	2	49	0	0	0	0	0	130

TRAFFIC DATA SERVICE

6280 San Ignacio Ave Suite C
San Jose, CA 95119

tdsbay@cs.com

File Name : 1 FINAL
Site Code : 00000001
Start Date : 9/17/2024
Page No : 2

Groups Printed- Vehicles

Start Time	LOS OLIVOS DR Southbound					SERRA AVE Westbound					LOS OLIVOS DR Northbound					Eastbound					Int. Total
	Right	Thru	Left	Peds	App. Total	Right	Thru	Left	Peds	App. Total	Right	Thru	Left	Peds	App. Total	Right	Thru	Left	Peds	App. Total	
09:00 AM	0	8	1	0	9	1	0	0	1	2	0	9	0	0	9	0	0	0	0	0	20
09:15 AM	0	6	0	0	6	1	0	1	0	2	0	6	0	0	6	0	0	0	0	0	14
09:30 AM	0	18	0	0	18	0	0	2	0	2	2	7	0	0	9	0	0	0	0	0	29
09:45 AM	0	7	1	0	8	0	0	1	0	1	0	7	0	0	7	0	0	0	0	0	16
Total	0	39	2	0	41	2	0	4	1	7	2	29	0	0	31	0	0	0	0	0	79
10:00 AM	0	5	1	0	6	2	0	0	0	2	1	8	0	0	9	0	0	0	0	0	17
10:15 AM	0	5	4	0	9	2	0	0	0	2	0	2	0	0	2	0	0	0	0	0	13
10:30 AM	0	3	0	1	4	0	0	1	2	3	2	7	0	0	9	0	0	0	0	0	16
10:45 AM	0	3	2	0	5	0	0	2	1	3	1	3	0	0	4	0	0	0	0	0	12
Total	0	16	7	1	24	4	0	3	3	10	4	20	0	0	24	0	0	0	0	0	58
11:00 AM	0	6	1	0	7	3	0	1	1	5	0	4	0	0	4	0	0	0	0	0	16
11:15 AM	0	12	0	0	12	0	0	1	0	1	1	3	0	0	4	0	0	0	0	0	17
11:30 AM	0	2	1	0	3	3	0	0	0	3	0	4	0	0	4	0	0	0	0	0	10
11:45 AM	0	5	0	0	5	2	0	1	1	4	2	4	0	0	6	0	0	0	0	0	15
Total	0	25	2	0	27	8	0	3	2	13	3	15	0	0	18	0	0	0	0	0	58
12:00 PM	0	3	1	0	4	1	0	0	1	2	0	6	0	1	7	0	0	0	0	0	13
12:15 PM	0	3	4	0	7	2	0	1	2	5	1	5	0	1	7	0	0	0	0	0	19
12:30 PM	0	13	2	0	15	0	0	0	0	0	2	6	0	0	8	0	0	0	0	0	23
12:45 PM	0	8	1	0	9	1	0	0	0	1	2	4	0	0	6	0	0	0	0	0	16
Total	0	27	8	0	35	4	0	1	3	8	5	21	0	2	28	0	0	0	0	0	71
01:00 PM	0	5	4	0	9	0	0	3	0	3	1	7	0	1	9	0	0	0	0	0	21
01:15 PM	0	6	1	0	7	3	0	1	1	5	1	5	0	0	6	0	0	0	0	0	18
01:30 PM	0	5	3	0	8	2	0	1	1	4	2	7	0	0	9	0	0	0	0	0	21
01:45 PM	0	7	2	0	9	2	0	2	0	4	0	4	0	0	4	0	0	0	0	0	17
Total	0	23	10	0	33	7	0	7	2	16	4	23	0	1	28	0	0	0	0	0	77
02:00 PM	0	2	0	0	2	1	0	1	1	3	0	8	0	0	8	0	0	0	0	0	13
02:15 PM	0	6	10	0	16	1	0	0	0	1	2	4	0	1	7	0	0	0	0	0	24
02:30 PM	0	7	6	0	13	0	0	2	3	5	2	7	0	1	10	0	0	0	0	0	28
02:45 PM	0	15	8	0	23	1	0	1	1	3	0	7	0	0	7	0	0	0	0	0	33
Total	0	30	24	0	54	3	0	4	5	12	4	26	0	2	32	0	0	0	0	0	98
03:00 PM	0	18	0	0	18	1	0	0	0	1	2	5	0	0	7	0	0	0	0	0	26
03:15 PM	0	10	3	0	13	0	0	0	0	0	1	10	0	1	12	0	0	0	0	0	25
03:30 PM	0	11	7	0	18	2	0	5	0	7	3	5	0	0	8	0	0	0	0	0	33
03:45 PM	0	13	4	0	17	3	0	1	0	4	1	14	0	0	15	0	0	0	0	0	36
Total	0	52	14	0	66	6	0	6	0	12	7	34	0	1	42	0	0	0	0	0	120
04:00 PM	0	16	8	0	24	2	0	1	1	4	2	7	0	1	10	0	0	0	0	0	38
04:15 PM	0	16	6	0	22	2	0	1	0	3	3	7	0	0	10	0	0	0	0	0	35
04:30 PM	0	20	5	2	27	0	0	0	1	1	0	9	0	0	9	0	0	0	0	0	37
04:45 PM	0	10	2	0	12	2	0	0	0	2	1	5	0	0	6	0	0	0	0	0	20
Total	0	62	21	2	85	6	0	2	2	10	6	28	0	1	35	0	0	0	0	0	130
05:00 PM	0	9	4	0	13	2	0	1	1	4	0	5	0	0	5	0	0	0	0	0	22
05:15 PM	0	23	4	0	27	3	0	5	1	9	1	6	0	0	7	0	0	0	0	0	43
05:30 PM	0	10	6	0	16	4	0	1	2	7	2	11	0	0	13	0	0	0	0	0	36
05:45 PM	0	11	4	0	15	2	0	0	0	2	0	8	0	0	8	0	0	0	0	0	25
Total	0	53	18	0	71	11	0	7	4	22	3	30	0	0	33	0	0	0	0	0	126
06:00 PM	0	28	7	0	35	4	0	3	1	8	0	9	0	2	11	0	0	0	0	0	54
06:15 PM	0	19	2	0	21	2	0	1	0	3	0	6	0	3	9	0	0	0	0	0	33

TRAFFIC DATA SERVICE

6280 San Ignacio Ave Suite C
San Jose, CA 95119

tdsbay@cs.com

File Name : 1 FINAL
Site Code : 00000001
Start Date : 9/17/2024
Page No : 3

Groups Printed- Vehicles

Start Time	LOS OLIVOS DR Southbound					SERRA AVE Westbound					LOS OLIVOS DR Northbound					Eastbound					Int. Total
	Right	Thru	Left	Peds	App. Total	Right	Thru	Left	Peds	App. Total	Right	Thru	Left	Peds	App. Total	Right	Thru	Left	Peds	App. Total	
06:30 PM	0	10	7	1	18	4	0	4	1	9	1	3	0	0	4	0	0	0	0	0	31
06:45 PM	0	9	6	4	19	2	0	5	3	10	0	7	0	0	7	0	0	0	0	0	36
Total	0	66	22	5	93	12	0	13	5	30	1	25	0	5	31	0	0	0	0	0	154
07:00 PM	0	8	4	2	14	2	0	2	1	5	2	10	0	2	14	0	0	0	0	0	33
07:15 PM	0	14	1	0	15	2	0	0	0	2	3	3	0	0	6	0	0	0	0	0	23
07:30 PM	0	15	3	0	18	2	0	1	0	3	1	2	0	0	3	0	0	0	0	0	24
07:45 PM	0	8	4	1	13	1	0	1	4	6	3	6	0	0	9	0	0	0	0	0	28
Total	0	45	12	3	60	7	0	4	5	16	9	21	0	2	32	0	0	0	0	0	108
08:00 PM	0	11	4	0	15	2	0	3	0	5	0	4	0	0	4	0	0	0	0	0	24
08:15 PM	0	7	3	0	10	2	0	2	1	5	0	4	0	0	4	0	0	0	0	0	19
08:30 PM	0	15	1	0	16	3	0	0	0	3	2	3	0	0	5	0	0	0	0	0	24
08:45 PM	0	3	2	1	6	3	0	1	2	6	1	0	0	0	1	0	0	0	0	0	13
Total	0	36	10	1	47	10	0	6	3	19	3	11	0	0	14	0	0	0	0	0	80
09:00 PM	0	6	0	0	6	0	0	0	3	3	0	1	0	0	1	0	0	0	0	0	10
09:15 PM	0	5	1	2	8	0	0	2	2	4	0	4	0	2	6	0	0	0	0	0	18
09:30 PM	0	2	1	0	3	2	0	2	3	7	0	3	0	0	3	0	0	0	0	0	13
09:45 PM	0	2	1	0	3	0	0	0	2	2	0	1	0	0	1	0	0	0	0	0	6
Total	0	15	3	2	20	2	0	4	10	16	0	9	0	2	11	0	0	0	0	0	47
10:00 PM	0	0	0	0	0	0	0	0	4	4	0	0	0	0	0	0	0	0	0	0	4
10:15 PM	0	1	0	0	1	2	0	1	1	4	0	3	0	0	3	0	0	0	0	0	8
10:30 PM	0	2	0	0	2	1	0	2	0	3	0	0	0	0	0	0	0	0	0	0	5
10:45 PM	0	2	0	0	2	0	0	0	0	0	0	2	0	0	2	0	0	0	0	0	4
Total	0	5	0	0	5	3	0	3	5	11	0	5	0	0	5	0	0	0	0	0	21
11:00 PM	0	0	2	0	2	0	0	0	0	0	0	1	0	0	1	0	0	0	0	0	3
11:15 PM	0	1	0	0	1	1	0	0	0	1	0	0	0	0	0	0	0	0	0	0	2
11:30 PM	0	1	0	0	1	0	0	0	0	0	0	0	0	0	0	0	0	0	0	0	1
11:45 PM	0	0	0	0	0	0	0	0	0	0	1	1	0	0	2	0	0	0	0	0	2
Total	0	2	2	0	4	1	0	0	0	1	1	2	0	0	3	0	0	0	0	0	8
Grand Total	0	573	180	15	768	119	0	78	64	261	67	381	0	19	467	0	0	0	0	0	1496
Apprch %	0	74.6	23.4	2		45.6	0	29.9	24.5		14.3	81.6	0	4.1		0	0	0	0		
Total %	0	38.3	12	1	51.3	8	0	5.2	4.3	17.4	4.5	25.5	0	1.3	31.2	0	0	0	0	0	

Start Time	LOS OLIVOS DR Southbound				SERRA AVE Westbound				LOS OLIVOS DR Northbound				Eastbound				Int. Total
	Right	Thru	Left	App. Total	Right	Thru	Left	App. Total	Right	Thru	Left	App. Total	Right	Thru	Left	App. Total	
Peak Hour Analysis From 07:00 AM to 10:45 AM - Peak 1 of 1																	
Peak Hour for Entire Intersection Begins at 07:45 AM																	
07:45 AM	0	11	2	13	2	0	1	3	2	10	0	12	0	0	0	0	28
08:00 AM	0	12	1	13	6	0	2	8	1	15	0	16	0	0	0	0	37
08:15 AM	0	8	2	10	5	0	3	8	0	11	0	11	0	0	0	0	29
08:30 AM	0	10	5	15	3	0	4	7	2	10	0	12	0	0	0	0	34
Total Volume	0	41	10	51	16	0	10	26	5	46	0	51	0	0	0	0	128
% App. Total	0	80.4	19.6		61.5	0	38.5		9.8	90.2	0		0	0	0		
PHF	.000	.854	.500	.850	.667	.000	.625	.813	.625	.767	.000	.797	.000	.000	.000	.000	.865

TRAFFIC DATA SERVICE

6280 San Ignacio Ave Suite C
San Jose, CA 95119

tdsbay@cs.com

File Name : 1 FINAL
Site Code : 00000001
Start Date : 9/17/2024
Page No : 4

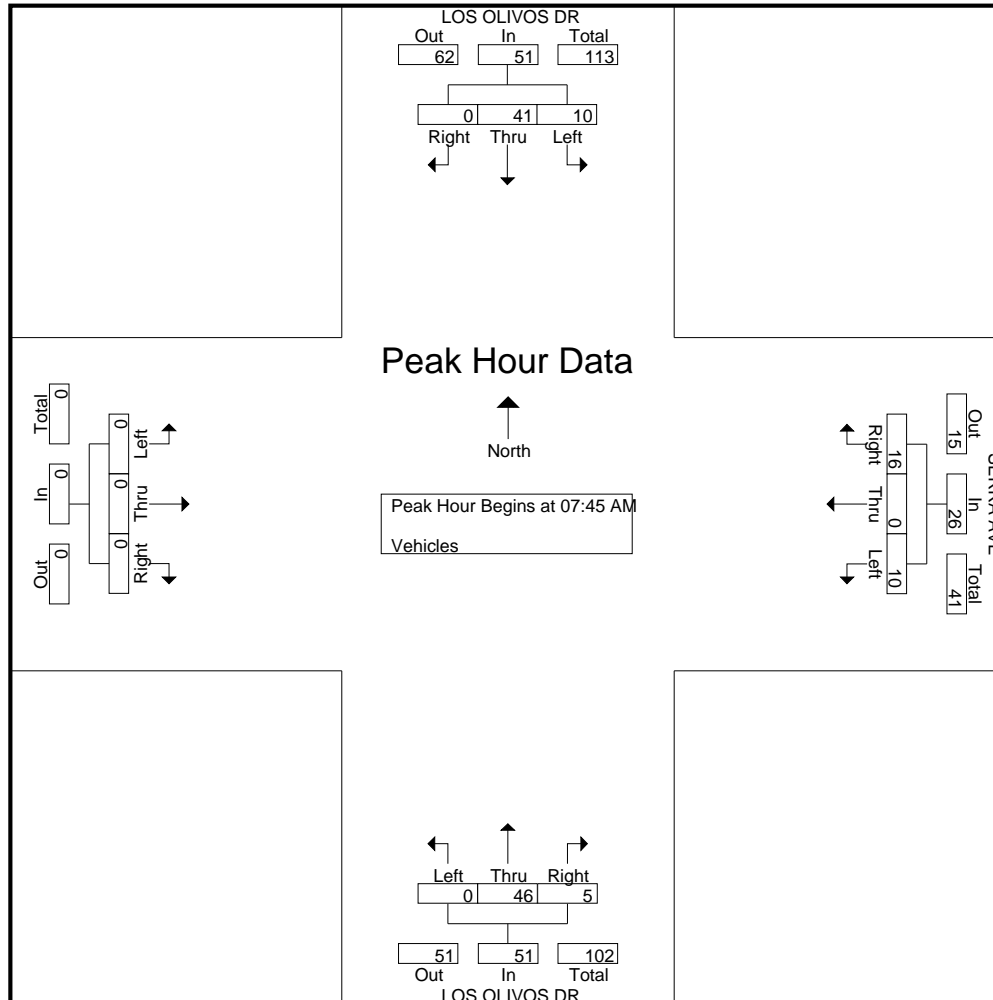

Peak Hour Analysis From 11:00 AM to 02:45 PM - Peak 1 of 1
Peak Hour for Entire Intersection Begins at 02:00 PM

02:00 PM	0	2	0	2	1	0	1	2	0	8	0	8	0	0	0	0	12
02:15 PM	0	6	10	16	1	0	0	1	2	4	0	6	0	0	0	0	23
02:30 PM	0	7	6	13	0	0	2	2	2	7	0	9	0	0	0	0	24
02:45 PM	0	15	8	23	1	0	1	2	0	7	0	7	0	0	0	0	32
Total Volume	0	30	24	54	3	0	4	7	4	26	0	30	0	0	0	0	91
% App. Total	0	55.6	44.4		42.9	0	57.1		13.3	86.7	0		0	0	0		
PHF	.000	.500	.600	.587	.750	.000	.500	.875	.500	.813	.000	.833	.000	.000	.000	.000	.711

TRAFFIC DATA SERVICE

6280 San Ignacio Ave Suite C
San Jose, CA 95119

tdsbay@cs.com

File Name : 1 FINAL
Site Code : 00000001
Start Date : 9/17/2024
Page No : 5

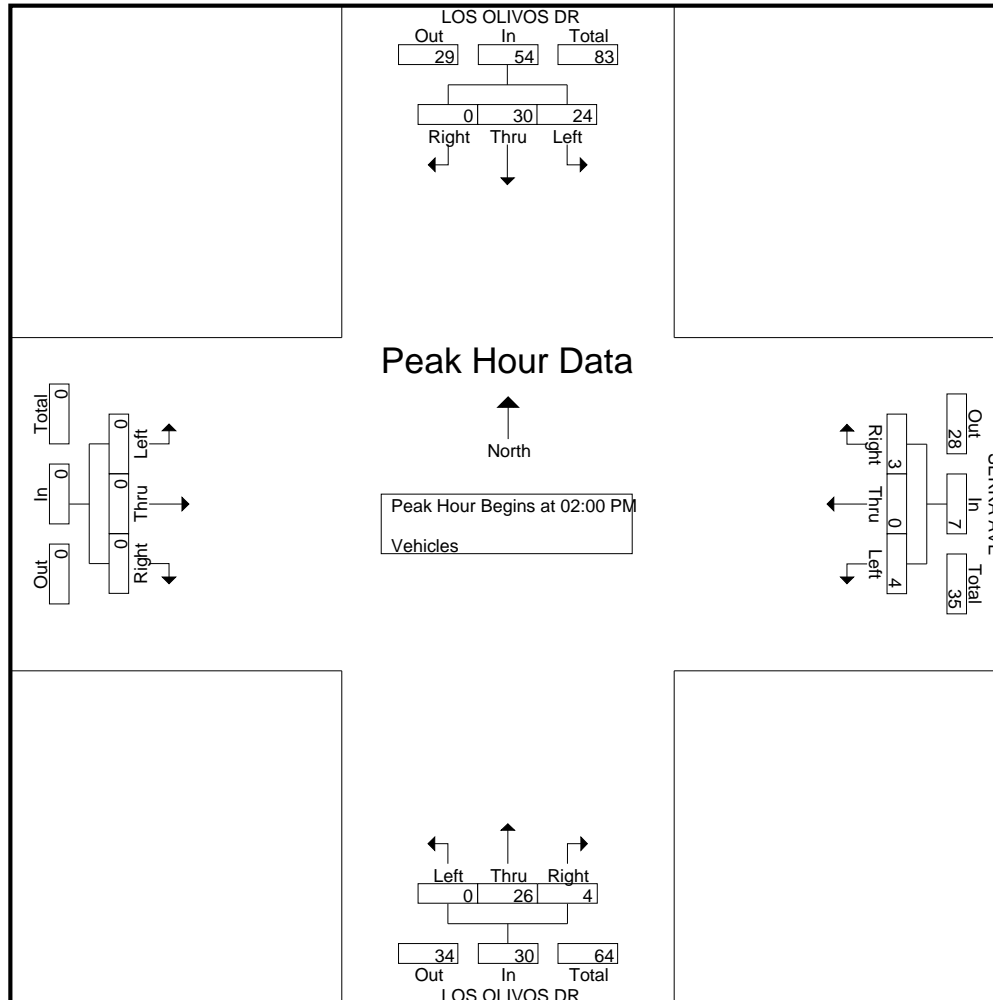

Peak Hour Analysis From 03:00 PM to 06:45 PM - Peak 1 of 1
Peak Hour for Entire Intersection Begins at 05:15 PM

05:15 PM	0	23	4	27	3	0	5	8	1	6	0	7	0	0	0	0	42
05:30 PM	0	10	6	16	4	0	1	5	2	11	0	13	0	0	0	0	34
05:45 PM	0	11	4	15	2	0	0	2	0	8	0	8	0	0	0	0	25
06:00 PM	0	28	7	35	4	0	3	7	0	9	0	9	0	0	0	0	51
Total Volume	0	72	21	93	13	0	9	22	3	34	0	37	0	0	0	0	152
% App. Total	0	77.4	22.6		59.1	0	40.9		8.1	91.9	0		0	0	0		
PHF	.000	.643	.750	.664	.813	.000	.450	.688	.375	.773	.000	.712	.000	.000	.000	.000	.745

TRAFFIC DATA SERVICE

6280 San Ignacio Ave Suite C
San Jose, CA 95119

tdsbay@cs.com

File Name : 1 FINAL
Site Code : 00000001
Start Date : 9/17/2024
Page No : 6

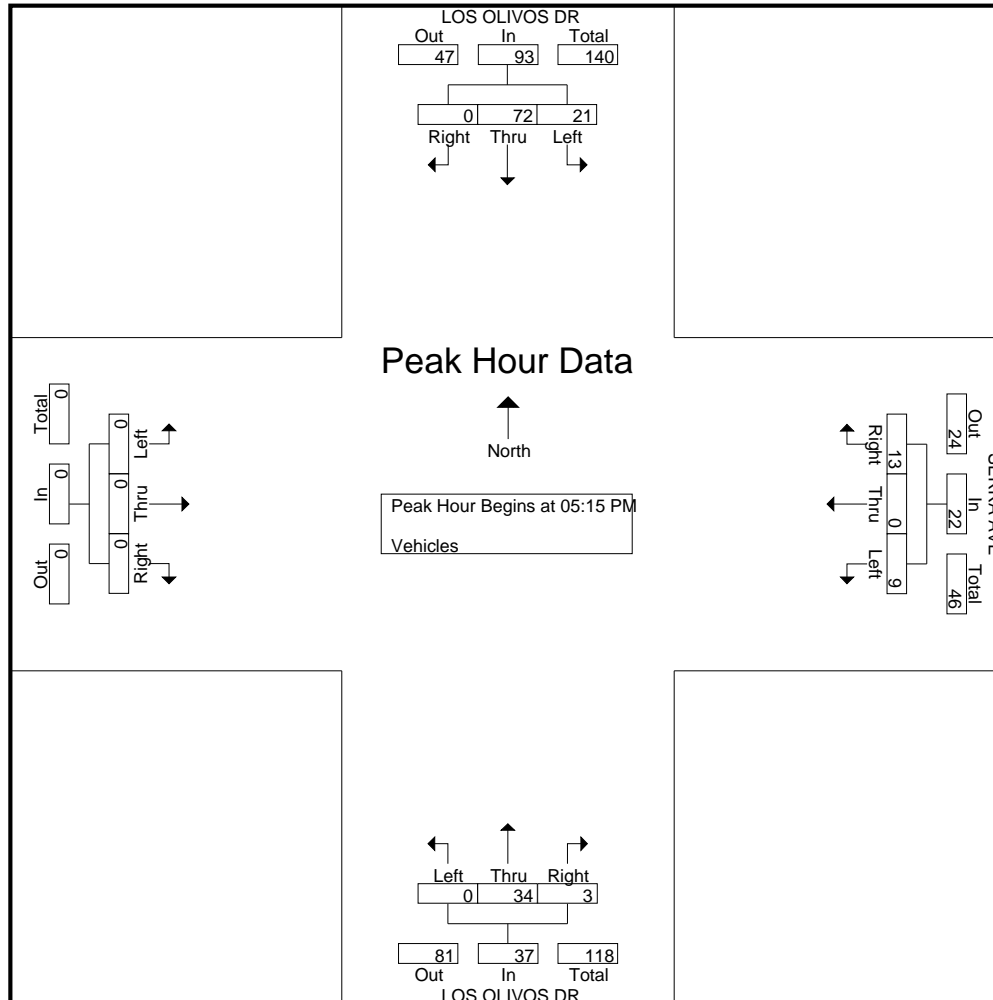

Peak Hour Analysis From 12:00 AM to 11:45 PM - Peak 1 of 1
Peak Hour for Entire Intersection Begins at 05:15 PM

05:15 PM	0	23	4	27	3	0	5	8	1	6	0	7	0	0	0	0	42
05:30 PM	0	10	6	16	4	0	1	5	2	11	0	13	0	0	0	0	34
05:45 PM	0	11	4	15	2	0	0	2	0	8	0	8	0	0	0	0	25
06:00 PM	0	28	7	35	4	0	3	7	0	9	0	9	0	0	0	0	51
Total Volume	0	72	21	93	13	0	9	22	3	34	0	37	0	0	0	0	152
% App. Total	0	77.4	22.6		59.1	0	40.9		8.1	91.9	0		0	0	0		
PHF	.000	.643	.750	.664	.813	.000	.450	.688	.375	.773	.000	.712	.000	.000	.000	.000	.745

TRAFFIC DATA SERVICE

6280 San Ignacio Ave Suite C
San Jose, CA 95119

tdsbay@cs.com

File Name : 1 FINAL
Site Code : 00000001
Start Date : 9/17/2024
Page No : 7

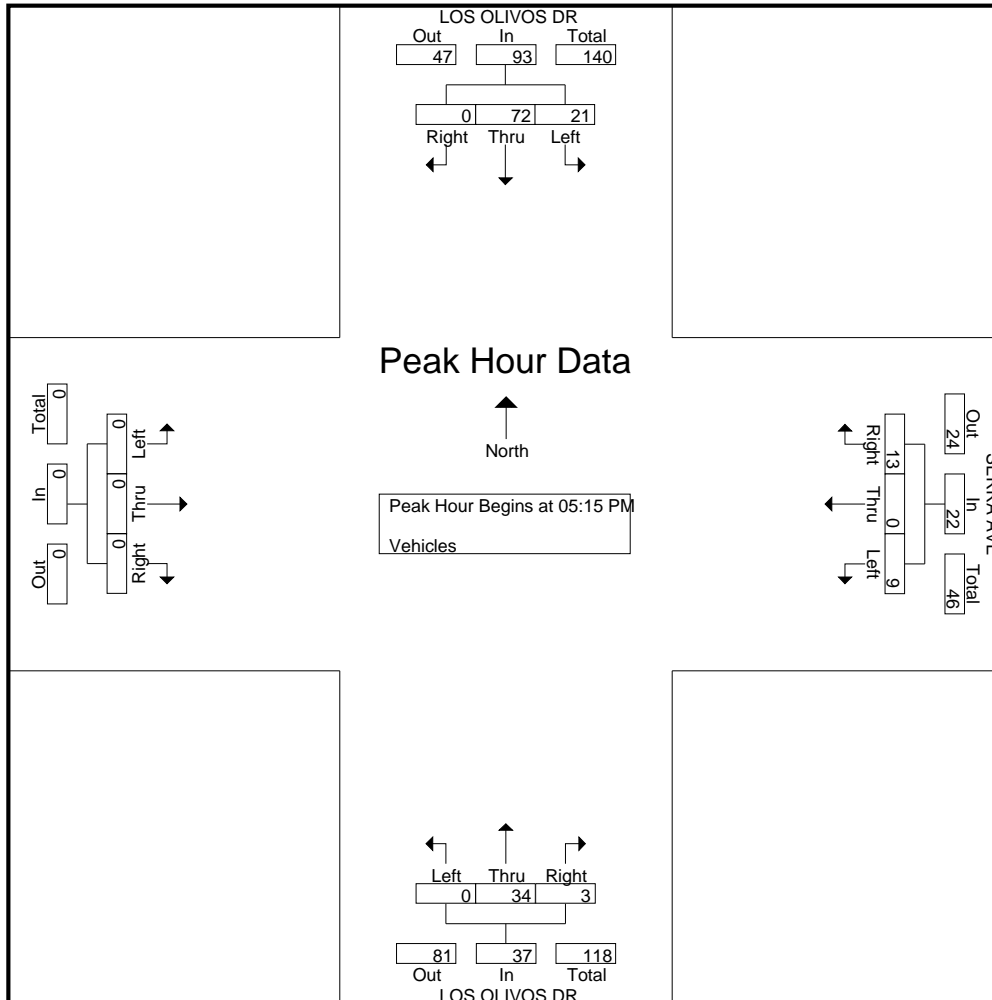

Traffic Data Service -- San Jose, CA Speed Report

CustomList-2494 -- English (ENU)

Datasets:

Site: [2] LOS OLIVOS DR BT HART AVE AND BRANNAN PL
Data type: Axle sensors - Paired (Class/Speed/Count)

Profile:

Included classes: 1, 2, 3, 4, 5, 6, 7, 8, 9, 10, 11, 12, 13
Speed range: 0 - 100 mph.
Direction: North (bound), P = North, Lane = 0-16
Name: Default Profile
Scheme: Vehicle classification (Scheme F)
Units: Non metric (ft, mi, ft/s, mph, lb, ton)

Column Legend:

- 0 [Time]** 24-hour time (0000 - 2359)
- 1 [Total]** Number in time step
- 2 [Vbin]** Speed bin totals
- 3 [vPace]** Speed at start of pace
- 4 [Pace%]** Percent in pace
- 5 [Mean]** Average speed
- 6 [Vpp]** Percentile speed

*** Tuesday, September 17, 2024**

Time	Total	Vbin	Vbin	Vbin	Vbin	Vbin	Vbin	Vbin	Vbin	Vbin	Vbin	Vbin	Vbin	Vbin	Vbin	Vbin	Vbin	vPace	Pace%	Mean	Vpp
<--		0	5	10	15	20	25	30	35	40	45	50	55	60	65	70	75	10	10		85
0000	1	0	0	0	0	1	0	0	0	0	0	0	0	0	0	0	0	13.2	100.0	23.1	-
0100	1	0	0	0	0	0	0	0	1	0	0	0	0	0	0	0	0	26.6	100.0	36.4	-
0200	1	0	0	0	0	1	0	0	0	0	0	0	0	0	0	0	0	14.8	100.0	24.6	-
0300	1	0	0	0	0	0	1	0	0	0	0	0	0	0	0	0	0	18.0	100.0	27.8	-
0400	1	0	0	0	0	1	0	0	0	0	0	0	0	0	0	0	0	15.4	100.0	25.3	-
0500	14	0	0	2	2	1	5	3	1	0	0	2	0	0	0	0	0	23.0	64.29	25.0	32.6
0600	14	0	0	0	0	1	4	7	2	0	0	0	0	0	0	0	0	26.8	92.86	30.7	35.3
0700	29	1	0	1	6	1	9	9	2	0	0	0	0	0	0	0	0	25.1	62.07	26.1	32.3
0800	66	0	0	4	11	13	20	15	3	0	0	0	0	0	0	0	0	22.1	59.09	25.5	31.6
0900	39	0	0	5	5	2	13	10	4	0	0	0	0	0	0	0	0	25.9	66.67	26.5	34.0
1000	28	0	0	1	4	6	10	4	3	0	0	0	0	0	0	0	0	20.1	60.71	26.4	34.2
1100	33	0	0	3	9	5	7	6	3	0	0	0	0	0	0	0	0	17.4	48.48	24.4	33.7
1200	34	0	1	4	3	6	12	7	1	0	0	0	0	0	0	0	0	22.3	70.59	24.9	31.7
1300	28	1	0	5	2	2	12	6	0	0	0	0	0	0	0	0	0	23.7	71.43	24.0	31.8
1400	39	0	1	4	6	9	8	10	1	0	0	0	0	0	0	0	0	22.5	48.72	24.8	33.2
1500	42	0	0	4	5	6	9	14	4	0	0	0	0	0	0	0	0	23.3	59.52	26.9	34.3
1600	33	0	0	3	5	4	11	7	3	0	0	0	0	0	0	0	0	21.4	60.61	25.7	32.3
1700	48	0	0	6	7	4	19	10	2	0	0	0	0	0	0	0	0	23.3	60.42	25.4	32.5
1800	36	0	0	2	5	9	14	4	2	0	0	0	0	0	0	0	0	18.5	72.22	24.8	30.8
1900	35	0	1	3	8	10	7	5	1	0	0	0	0	0	0	0	0	22.4	57.14	23.3	31.0
2000	17	0	0	0	1	3	8	5	0	0	0	0	0	0	0	0	0	22.9	94.12	27.3	31.1
2100	10	0	0	0	1	2	6	1	0	0	0	0	0	0	0	0	0	22.1	90.00	26.0	-
2200	8	0	0	0	1	1	4	1	1	0	0	0	0	0	0	0	0	26.1	75.00	27.8	-
2300	3	0	0	0	0	0	3	0	0	0	0	0	0	0	0	0	0	17.9	100.0	27.0	-
07-19	455	2	2	42	68	67	144	102	28	0	0	0	0	0	0	0	0	23.2	56.04	25.5	32.4
06-22	531	2	3	45	78	83	169	120	31	0	0	0	0	0	0	0	0	23.2	58.38	25.6	32.3
06-00	542	2	3	45	79	84	176	121	32	0	0	0	0	0	0	0	0	23.2	58.67	25.6	32.3
00-00	561	2	3	47	81	87	183	124	34	0	0	0	0	0	0	0	0	23.2	58.82	25.6	32.3

Peak step 8:00 (66) AM Peak step 8:00 (66) PM Peak step 17:00 (48)

*** Wednesday, September 18, 2024**

Time	Total	Vbin	Vbin	Vbin	Vbin	Vbin	Vbin	Vbin	Vbin	Vbin	Vbin	Vbin	Vbin	Vbin	Vbin	Vbin	Vbin	vPace	Pace%	Mean	Vpp
<--		0	5	10	15	20	25	30	35	40	45	50	55	60	65	70	75	10	10		85
		5	10	15	20	25	30	35	40	45	50	55	60	65	70	75	100				
0000	1	0	0	1	0	0	0	0	0	0	0	0	0	0	0	0	0	4.3	100.0	14.1	-
0100	1	0	0	0	0	0	0	0	0	1	0	0	0	0	0	0	0	28.4	100.0	38.2	-
0200	0	0	0	0	0	0	0	0	0	0	0	0	0	0	0	0	0	-	-	-	-
0300	0	0	0	0	0	0	0	0	0	0	0	0	0	0	0	0	0	-	-	-	-
0400	2	0	0	1	0	1	0	0	0	0	0	0	0	0	0	0	0	1.6	50.00	17.6	-
0500	13	0	0	1	1	1	3	6	1	0	0	0	0	0	0	0	0	22.6	69.23	27.9	33.4
0600	16	0	1	0	3	0	7	5	0	0	0	0	0	0	0	0	0	25.2	75.00	26.0	34.8
0700	29	0	0	1	4	4	12	4	4	0	0	0	0	0	0	0	0	22.4	65.52	26.9	33.8
0800	53	0	0	2	11	12	13	14	1	0	0	0	0	0	0	0	0	22.4	62.26	25.0	31.9
0900	42	0	0	4	7	7	13	8	2	1	0	0	0	0	0	0	0	21.9	54.76	25.1	31.8
1000	27	0	1	4	0	3	11	7	1	0	0	0	0	0	0	0	0	22.3	70.37	25.6	31.6
1100	29	0	0	2	8	3	6	9	1	0	0	0	0	0	0	0	0	25.2	51.72	25.2	34.3
1200	40	1	0	1	6	6	11	11	4	0	0	0	0	0	0	0	0	24.6	60.00	26.9	34.4
1300	36	0	0	3	6	5	12	9	1	0	0	0	0	0	0	0	0	23.4	66.67	25.4	32.2
1400	38	0	0	6	8	5	11	8	0	0	0	0	0	0	0	0	0	24.3	50.00	23.8	32.5
1500	33	0	0	7	3	6	12	5	0	0	0	0	0	0	0	0	0	22.0	66.67	23.6	30.7
1600	46	0	1	3	5	6	16	10	4	1	0	0	0	0	0	0	0	25.4	58.70	26.6	33.4
1700	45	0	0	1	8	2	20	11	2	1	0	0	0	0	0	0	0	24.2	71.11	27.2	32.3
1800	45	0	1	1	12	6	15	9	1	0	0	0	0	0	0	0	0	21.4	57.78	24.9	31.0
1900	25	0	0	3	4	1	8	8	0	1	0	0	0	0	0	0	0	23.6	64.00	25.7	33.0
2000	17	0	0	1	3	4	6	3	0	0	0	0	0	0	0	0	0	20.8	70.59	24.9	30.6
2100	16	0	0	0	1	5	4	6	0	0	0	0	0	0	0	0	0	21.0	81.25	26.9	31.2
2200	2	0	0	0	1	1	0	0	0	0	0	0	0	0	0	0	0	12.8	100.0	20.8	-
2300	4	0	0	1	1	0	1	1	0	0	0	0	0	0	0	0	0	6.0	50.00	21.9	-
07-19	463	1	3	35	78	65	152	105	21	3	0	0	0	0	0	0	0	22.4	56.59	25.5	32.0
06-22	537	1	4	39	89	75	177	127	21	4	0	0	0	0	0	0	0	22.4	57.17	25.6	32.0
06-00	543	1	4	40	91	76	178	128	21	4	0	0	0	0	0	0	0	22.4	56.91	25.5	32.0
00-00	560	1	4	43	92	78	181	134	23	4	0	0	0	0	0	0	0	22.4	56.79	25.6	32.0

Peak step 8:00 (53) AM Peak step 8:00 (53) PM Peak step 16:00 (46)

*** Thursday, September 19, 2024**

Time	Total	Vbin	Vbin	Vbin	Vbin	Vbin	Vbin	Vbin	Vbin	Vbin	Vbin	Vbin	Vbin	Vbin	Vbin	Vbin	Vbin	vPace	Pace%	Mean	Vpp
<--		0	5	10	15	20	25	30	35	40	45	50	55	60	65	70	75	10	10		85
		5	10	15	20	25	30	35	40	45	50	55	60	65	70	75	100				
0000	1	0	0	0	0	0	0	1	0	0	0	0	0	0	0	0	0	22.9	100.0	32.7	-
0100	0	0	0	0	0	0	0	0	0	0	0	0	0	0	0	0	0	-	-	-	-
0200	0	0	0	0	0	0	0	0	0	0	0	0	0	0	0	0	0	-	-	-	-
0300	2	0	0	1	0	0	0	1	0	0	0	0	0	0	0	0	0	4.0	50.00	22.9	-
0400	3	0	0	1	0	1	1	0	0	0	0	0	0	0	0	0	0	19.2	66.67	21.4	-
0500	12	0	0	2	1	1	3	5	0	0	0	0	0	0	0	0	0	24.4	75.00	25.9	33.7
0600	9	0	0	0	0	1	5	3	0	0	0	0	0	0	0	0	0	22.7	88.89	28.1	-
0700	28	0	0	1	4	7	8	7	1	0	0	0	0	0	0	0	0	23.7	67.86	26.2	33.3
0800	43	0	0	3	11	7	9	11	2	0	0	0	0	0	0	0	0	22.4	48.84	24.7	32.1
0900	38	0	2	4	7	4	11	10	0	0	0	0	0	0	0	0	0	24.0	55.26	24.0	32.2
1000	31	0	0	5	5	3	9	6	3	0	0	0	0	0	0	0	0	25.5	54.84	25.1	32.9
1100	20	0	0	3	3	1	9	2	2	0	0	0	0	0	0	0	0	21.6	60.00	24.9	31.3
1200	27	0	0	0	4	3	9	6	5	0	0	0	0	0	0	0	0	28.0	59.26	28.2	36.4
1300	43	0	0	2	6	9	16	9	0	1	0	0	0	0	0	0	0	22.4	67.44	25.6	32.0
1400	41	0	0	3	4	5	15	12	2	0	0	0	0	0	0	0	0	23.5	68.29	26.6	32.7
1500	36	0	0	5	5	3	9	12	0	1	1	0	0	0	0	0	0	24.7	63.89	26.2	32.8
1600	32	0	0	1	8	4	9	7	3	0	0	0	0	0	0	0	0	22.9	56.25	26.1	33.5
1700	36	0	0	2	13	5	7	7	1	1	0	0	0	0	0	0	0	16.2	58.33	24.1	33.0
1800	48	0	0	1	6	2	22	15	2	0	0	0	0	0	0	0	0	24.6	79.17	27.8	33.7
1900	36	0	1	0	5	6	15	6	3	0	0	0	0	0	0	0	0	22.6	69.44	26.4	32.4
2000	10	0	0	1	2	1	2	4	0	0	0	0	0	0	0	0	0	23.2	70.00	24.7	-
2100	13	0	0	1	0	4	5	3	0	0	0	0	0	0	0	0	0	21.4	76.92	25.3	31.5
2200	4	0	0	0	0	1	1	2	0	0	0	0	0	0	0	0	0	22.7	100.0	29.4	-
2300	4	0	0	0	0	0	3	1	0	0	0	0	0	0	0	0	0	21.9	100.0	28.9	-
07-19	423	0	2	30	76	53	133	104	21	3	1	0	0	0	0	0	0	24.0	56.74	25.8	32.8
06-22	491	0	3	32	83	65	160	120	24	3	1	0	0	0	0	0	0	24.0	58.86	25.8	32.7
06-00	499	0	3	32	83	66	164	123	24	3	1	0	0	0	0	0	0	24.0	59.52	25.9	32.7
00-00	517	0	3	36	84	68	168	130	24	3	1	0	0	0	0	0	0	24.0	59.77	25.9	32.7

Peak step 18:00 (48) AM Peak step 8:00 (43) PM Peak step 18:00 (48)

*** Grand Total**

Time	Total	Vbin	Vbin	Vbin	Vbin	Vbin	Vbin	Vbin	Vbin	Vbin	Vbin	Vbin	Vbin	Vbin	Vbin	Vbin	Vbin	vPace	Pace%	Mean	Vpp
<--		0	5	10	15	20	25	30	35	40	45	50	55	60	65	70	75	10	10		85
--		5	10	15	20	25	30	35	40	45	50	55	60	65	70	75	100				
--	1638	3	10	126	257	233	532	388	81	7	1	0	0	0	0	0	0	23.2	57.94	25.7	32.3

Traffic Data Service -- San Jose, CA Speed Report

CustomList-2495 -- English (ENU)

Datasets:

Site: [2] LOS OLIVOS DR BT HART AVE AND BRANNAN PL
Data type: Axle sensors - Paired (Class/Speed/Count)

Profile:

Included classes: 1, 2, 3, 4, 5, 6, 7, 8, 9, 10, 11, 12, 13
Speed range: 0 - 100 mph.
Direction: South (bound), P = North, Lane = 0-16
Name: Default Profile
Scheme: Vehicle classification (Scheme F)
Units: Non metric (ft, mi, ft/s, mph, lb, ton)

Column Legend:

- 0 [Time]** 24-hour time (0000 - 2359)
- 1 [Total]** Number in time step
- 2 [Vbin]** Speed bin totals
- 3 [vPace]** Speed at start of pace
- 4 [Pace%]** Percent in pace
- 5 [Mean]** Average speed
- 6 [Vpp]** Percentile speed

*** Tuesday, September 17, 2024**

Time	Total	Vbin	Vbin	Vbin	Vbin	Vbin	Vbin	Vbin	Vbin	Vbin	Vbin	Vbin	Vbin	Vbin	Vbin	Vbin	Vbin	Vbin	vPace	Pace%	Mean	Vpp
<--		0	5	10	15	20	25	30	35	40	45	50	55	60	65	70	75	10	10		85	
0000	5	0	0	0	0	1	3	1	0	0	0	0	0	0	0	0	0	0	22.1	100.0	27.2	-
0100	0	0	0	0	0	0	0	0	0	0	0	0	0	0	0	0	0	0	-	-	-	-
0200	0	0	0	0	0	0	0	0	0	0	0	0	0	0	0	0	0	0	-	-	-	-
0300	2	0	0	0	0	1	0	1	0	0	0	0	0	0	0	0	0	0	20.4	100.0	26.2	-
0400	1	0	0	0	1	0	0	0	0	0	0	0	0	0	0	0	0	0	7.9	100.0	17.8	-
0500	2	0	0	0	0	1	1	0	0	0	0	0	0	0	0	0	0	0	16.9	100.0	23.9	-
0600	6	0	0	0	1	1	2	2	0	0	0	0	0	0	0	0	0	0	22.8	83.33	27.1	-
0700	33	0	1	2	5	5	12	6	1	1	0	0	0	0	0	0	0	0	22.0	60.61	25.6	32.2
0800	47	0	1	2	5	9	14	13	2	1	0	0	0	0	0	0	0	0	23.0	65.96	26.2	32.9
0900	43	0	0	4	4	8	16	11	0	0	0	0	0	0	0	0	0	0	23.6	72.09	25.4	32.3
1000	26	0	0	1	1	3	13	6	1	1	0	0	0	0	0	0	0	0	22.4	76.92	28.4	32.2
1100	33	0	0	1	4	4	12	9	2	1	0	0	0	0	0	0	0	0	24.6	63.64	27.6	34.0
1200	38	0	1	2	2	7	18	7	1	0	0	0	0	0	0	0	0	0	22.9	78.95	26.4	32.2
1300	33	0	0	1	6	7	11	6	2	0	0	0	0	0	0	0	0	0	20.8	63.64	25.8	30.6
1400	58	0	6	2	3	8	13	23	2	1	0	0	0	0	0	0	0	0	24.0	63.79	26.2	33.6
1500	75	0	0	1	6	13	22	25	6	1	1	0	0	0	0	0	0	0	25.3	64.00	28.2	34.0
1600	89	0	0	2	8	15	33	24	6	1	0	0	0	0	0	0	0	0	23.9	66.29	27.7	33.1
1700	80	0	0	3	10	11	24	22	8	2	0	0	0	0	0	0	0	0	23.7	63.75	27.8	34.6
1800	94	0	0	10	6	20	39	14	3	2	0	0	0	0	0	0	0	0	21.9	70.21	25.8	31.2
1900	62	0	0	0	4	17	21	13	6	0	1	0	0	0	0	0	0	0	20.1	61.29	27.6	33.6
2000	51	0	0	4	5	14	24	2	1	1	0	0	0	0	0	0	0	0	19.1	76.47	24.6	28.5
2100	19	0	0	0	1	1	11	4	1	1	0	0	0	0	0	0	0	0	20.4	78.95	28.8	33.7
2200	6	0	0	0	1	1	3	1	0	0	0	0	0	0	0	0	0	0	24.5	83.33	26.5	-
2300	4	0	0	0	0	1	3	0	0	0	0	0	0	0	0	0	0	0	19.1	100.0	25.6	-
07-19	649	0	9	31	60	110	227	166	34	11	1	0	0	0	0	0	0	0	23.7	63.94	26.8	32.8
06-22	787	0	9	35	71	143	285	187	42	13	2	0	0	0	0	0	0	0	23.7	64.04	26.8	32.8
06-00	797	0	9	35	72	145	291	188	42	13	2	0	0	0	0	0	0	0	23.7	64.12	26.8	32.8
00-00	807	0	9	35	73	148	295	190	42	13	2	0	0	0	0	0	0	0	23.7	64.06	26.8	32.7

Peak step 18:00 (94) AM Peak step 8:00 (47) PM Peak step 18:00 (94)

*** Wednesday, September 18, 2024**

Time	Total	Vbin	Vbin	Vbin	Vbin	Vbin	Vbin	Vbin	Vbin	Vbin	Vbin	Vbin	Vbin	Vbin	Vbin	Vbin	Vbin	vPace	Pace%	Mean	Vpp
<--		0	5	10	15	20	25	30	35	40	45	50	55	60	65	70	75	10	10		85
		5	10	15	20	25	30	35	40	45	50	55	60	65	70	75	100				
0000	3	0	0	1	0	1	1	0	0	0	0	0	0	0	0	0	0	11.6	66.67	21.5	-
0100	2	0	0	1	0	0	0	0	1	0	0	0	0	0	0	0	0	3.6	50.00	25.7	-
0200	0	0	0	0	0	0	0	0	0	0	0	0	0	0	0	0	0	-	-	-	-
0300	1	0	0	0	0	0	1	0	0	0	0	0	0	0	0	0	0	19.5	100.0	29.3	-
0400	1	0	0	0	0	0	0	1	0	0	0	0	0	0	0	0	0	21.8	100.0	31.6	-
0500	3	0	0	0	0	0	3	0	0	0	0	0	0	0	0	0	0	16.2	100.0	25.6	-
0600	5	0	0	0	0	0	4	1	0	0	0	0	0	0	0	0	0	20.2	100.0	28.3	-
0700	24	0	1	1	3	4	6	5	3	1	0	0	0	0	0	0	0	27.8	54.17	27.6	37.7
0800	58	0	0	2	4	15	22	14	1	0	0	0	0	0	0	0	0	23.0	74.14	26.5	31.5
0900	31	0	0	1	4	6	11	8	1	0	0	0	0	0	0	0	0	21.7	64.52	26.1	32.1
1000	40	0	0	3	4	8	11	12	2	0	0	0	0	0	0	0	0	22.7	62.50	26.0	32.4
1100	37	0	0	1	2	6	12	13	3	0	0	0	0	0	0	0	0	24.5	75.68	27.8	33.4
1200	40	1	0	0	5	8	13	9	4	0	0	0	0	0	0	0	0	25.6	57.50	26.2	33.0
1300	48	1	0	2	6	6	14	13	6	0	0	0	0	0	0	0	0	24.0	58.33	26.9	34.5
1400	68	0	0	3	10	10	29	14	1	1	0	0	0	0	0	0	0	23.5	69.12	26.0	32.1
1500	63	0	0	4	3	10	21	18	6	1	0	0	0	0	0	0	0	22.7	65.08	27.8	34.0
1600	83	0	0	1	12	11	29	19	7	4	0	0	0	0	0	0	0	25.2	59.04	28.0	34.8
1700	90	0	0	4	8	10	38	23	7	0	0	0	0	0	0	0	0	22.4	72.22	27.3	32.0
1800	100	0	1	4	14	18	37	20	4	2	0	0	0	0	0	0	0	22.5	67.00	26.1	31.8
1900	62	0	1	1	6	9	23	17	4	1	0	0	0	0	0	0	0	23.2	69.35	27.6	32.8
2000	37	0	1	1	7	7	16	4	1	0	0	0	0	0	0	0	0	21.1	67.57	24.3	29.9
2100	29	0	0	1	5	7	12	3	1	0	0	0	0	0	0	0	0	21.6	75.86	24.7	30.1
2200	9	0	0	0	1	3	3	2	0	0	0	0	0	0	0	0	0	22.9	77.78	26.3	-
2300	3	0	0	0	1	0	1	1	0	0	0	0	0	0	0	0	0	23.0	66.67	24.5	-
07-19	682	2	2	26	75	112	243	168	45	9	0	0	0	0	0	0	0	22.7	63.93	26.9	32.7
06-22	815	2	4	29	93	135	298	193	51	10	0	0	0	0	0	0	0	22.7	64.79	26.7	32.5
06-00	827	2	4	29	95	138	302	196	51	10	0	0	0	0	0	0	0	22.7	64.69	26.7	32.5
00-00	837	2	4	31	95	139	307	197	52	10	0	0	0	0	0	0	0	22.7	64.64	26.7	32.5

Peak step 18:00 (100) AM Peak step 8:00 (58) PM Peak step 18:00 (100)

*** Thursday, September 19, 2024**

Time	Total	Vbin	Vbin	Vbin	Vbin	Vbin	Vbin	Vbin	Vbin	Vbin	Vbin	Vbin	Vbin	Vbin	Vbin	Vbin	Vbin	vPace	Pace%	Mean	Vpp
<--		0	5	10	15	20	25	30	35	40	45	50	55	60	65	70	75	10	10		85
		5	10	15	20	25	30	35	40	45	50	55	60	65	70	75	100				
0000	3	0	0	0	1	0	1	0	1	0	0	0	0	0	0	0	0	27.4	66.67	26.7	-
0100	1	0	0	0	0	0	1	0	0	0	0	0	0	0	0	0	0	16.6	100.0	26.4	-
0200	1	0	0	0	0	0	1	0	0	0	0	0	0	0	0	0	0	15.3	100.0	25.1	-
0300	2	0	0	0	0	2	0	0	0	0	0	0	0	0	0	0	0	13.9	100.0	23.3	-
0400	3	0	0	0	0	0	2	1	0	0	0	0	0	0	0	0	0	27.8	100.0	33.9	-
0500	3	0	0	0	1	1	1	0	0	0	0	0	0	0	0	0	0	16.3	100.0	22.3	-
0600	6	0	0	0	1	2	2	1	0	0	0	0	0	0	0	0	0	19.2	66.67	25.1	-
0700	31	0	0	2	2	6	9	9	3	0	0	0	0	0	0	0	0	21.7	64.52	27.0	33.7
0800	46	0	0	3	9	7	15	8	4	0	0	0	0	0	0	0	0	21.9	56.52	25.4	33.7
0900	36	0	0	2	7	10	11	5	1	0	0	0	0	0	0	0	0	18.0	63.89	24.5	31.3
1000	40	0	0	0	3	13	14	7	2	1	0	0	0	0	0	0	0	20.9	80.00	26.8	30.7
1100	37	0	1	1	0	7	9	14	5	0	0	0	0	0	0	0	0	23.3	78.38	28.6	34.8
1200	38	0	0	1	0	5	16	12	2	1	1	0	0	0	0	0	0	24.3	76.32	29.1	33.9
1300	38	1	0	1	0	4	18	11	3	0	0	0	0	0	0	0	0	23.9	86.84	28.5	32.9
1400	67	0	0	4	5	8	23	17	8	1	1	0	0	0	0	0	0	23.9	62.69	28.3	35.3
1500	75	0	2	1	5	8	31	21	5	2	0	0	0	0	0	0	0	24.6	73.33	28.3	33.7
1600	56	0	0	1	4	7	18	21	5	0	0	0	0	0	0	0	0	23.4	73.21	28.8	33.2
1700	87	0	0	0	15	5	41	15	9	2	0	0	0	0	0	0	0	23.4	66.67	27.5	33.6
1800	74	0	0	1	14	12	30	15	2	0	0	0	0	0	0	0	0	21.4	67.57	25.9	30.8
1900	74	0	0	3	7	19	34	9	1	1	0	0	0	0	0	0	0	20.5	74.32	25.6	29.9
2000	49	0	0	4	3	9	23	6	4	0	0	0	0	0	0	0	0	21.0	69.39	25.8	31.1
2100	19	0	0	1	0	5	9	4	0	0	0	0	0	0	0	0	0	20.8	84.21	26.5	30.6
2200	6	0	0	0	0	2	2	2	0	0	0	0	0	0	0	0	0	20.4	83.33	26.8	-
2300	5	0	0	0	0	1	2	2	0	0	0	0	0	0	0	0	0	22.3	100.0	27.8	-
07-19	625	1	3	17	64	92	235	155	49	7	2	0	0	0	0	0	0	23.9	66.88	27.4	33.1
06-22	773	1	3	25	75	127	303	175	54	8	2	0	0	0	0	0	0	23.9	66.62	27.1	32.7
06-00	784	1	3	25	75	130	307	179	54	8	2	0	0	0	0	0	0	23.9	66.84	27.1	32.6
00-00	797	1	3	25	77	133	311	181	56	8	2	0	0	0	0	0	0	23.3	66.62	27.1	32.6

Peak step 17:00 (87) AM Peak step 8:00 (46) PM Peak step 17:00 (87)

*** Grand Total**

Time	Total	Vbin	Vbin	Vbin	Vbin	Vbin	Vbin	Vbin	Vbin	Vbin	Vbin	Vbin	Vbin	Vbin	Vbin	Vbin	Vbin	vPace	Pace%	Mean	Vpp
<--		0	5	10	15	20	25	30	35	40	45	50	55	60	65	70	75	10	10		85
--		5	10	15	20	25	30	35	40	45	50	55	60	65	70	75	100				
--	2441	3	16	91	245	420	913	568	150	31	4	0	0	0	0	0	0	23.0	64.89	26.9	32.5

Traffic Data Service -- San Jose, CA Speed Report

CustomList-2496 -- English (ENU)

Datasets:

Site: [3] LOS OLIVOS DR BT JOHNSON PL AND AUSTIN PL
Data type: Axle sensors - Paired (Class/Speed/Count)

Profile:

Included classes: 1, 2, 3, 4, 5, 6, 7, 8, 9, 10, 11, 12, 13
Speed range: 0 - 100 mph.
Direction: North (bound), P = North, Lane = 0-16
Name: Default Profile
Scheme: Vehicle classification (Scheme F)
Units: Non metric (ft, mi, ft/s, mph, lb, ton)

Column Legend:

- 0 [Time]** 24-hour time (0000 - 2359)
- 1 [Total]** Number in time step
- 2 [Vbin]** Speed bin totals
- 3 [vPace]** Speed at start of pace
- 4 [Pace%]** Percent in pace
- 5 [Mean]** Average speed
- 6 [Vpp]** Percentile speed

*** Tuesday, September 17, 2024**

Time	Total	Vbin	Vbin	Vbin	Vbin	Vbin	Vbin	Vbin	Vbin	Vbin	Vbin	Vbin	Vbin	Vbin	Vbin	Vbin	Vbin	vPace	Pace%	Mean	Vpp
<--		0	5	10	15	20	25	30	35	40	45	50	55	60	65	70	75	10	10		85
0000	1	0	0	0	0	1	0	0	0	0	0	0	0	0	0	0	0	13.9	100.0	23.7	-
0100	2	0	0	0	0	1	0	1	0	0	0	0	0	0	0	0	0	12.2	50.00	27.6	-
0200	2	0	0	0	0	0	2	0	0	0	0	0	0	0	0	0	0	19.1	100.0	27.9	-
0300	0	0	0	0	0	0	0	0	0	0	0	0	0	0	0	0	0	-	-	-	-
0400	1	0	0	1	0	0	0	0	0	0	0	0	0	0	0	0	0	0.8	100.0	10.6	-
0500	6	0	0	0	1	3	0	2	0	0	0	0	0	0	0	0	0	14.5	66.67	25.0	-
0600	6	0	0	0	1	1	2	1	0	1	0	0	0	0	0	0	0	18.0	50.00	28.5	-
0700	14	0	0	0	1	5	4	3	1	0	0	0	0	0	0	0	0	19.3	64.29	27.4	33.5
0800	41	0	0	0	2	9	16	9	4	1	0	0	0	0	0	0	0	24.4	65.85	28.3	34.2
0900	28	0	0	0	1	3	9	10	3	1	1	0	0	0	0	0	0	25.1	67.86	30.5	35.8
1000	19	0	0	1	0	3	3	7	4	1	0	0	0	0	0	0	0	26.2	63.16	30.4	38.8
1100	19	1	0	0	0	4	4	6	4	0	0	0	0	0	0	0	0	27.1	68.42	28.4	35.7
1200	27	0	0	2	0	5	8	10	2	0	0	0	0	0	0	0	0	23.9	66.67	27.9	33.7
1300	25	0	0	0	2	3	9	8	2	1	0	0	0	0	0	0	0	22.0	72.00	29.0	34.0
1400	30	0	0	1	2	2	12	6	7	0	0	0	0	0	0	0	0	26.2	63.33	28.9	36.2
1500	33	0	0	1	2	5	12	7	3	2	1	0	0	0	0	0	0	23.8	66.67	29.2	37.4
1600	37	0	0	1	2	2	14	14	3	1	0	0	0	0	0	0	0	24.4	78.38	29.6	33.8
1700	44	0	0	1	3	13	16	8	2	1	0	0	0	0	0	0	0	22.1	72.73	27.0	32.3
1800	28	0	1	1	5	6	7	8	0	0	0	0	0	0	0	0	0	21.3	60.71	25.1	31.9
1900	27	0	0	0	5	6	12	3	1	0	0	0	0	0	0	0	0	21.8	70.37	25.6	31.3
2000	15	1	0	0	0	2	5	6	1	0	0	0	0	0	0	0	0	25.9	80.00	27.9	34.3
2100	12	0	0	0	0	2	7	2	1	0	0	0	0	0	0	0	0	25.7	83.33	27.9	34.2
2200	5	0	1	1	0	1	2	0	0	0	0	0	0	0	0	0	0	17.3	60.00	19.0	-
2300	6	0	0	0	0	2	2	1	1	0	0	0	0	0	0	0	0	17.9	66.67	27.6	-
07-19	345	1	1	8	20	60	114	96	35	8	2	0	0	0	0	0	0	24.3	63.48	28.4	34.1
06-22	405	2	1	8	26	71	140	108	38	9	2	0	0	0	0	0	0	24.3	63.95	28.2	33.9
06-00	416	2	2	9	26	74	144	109	39	9	2	0	0	0	0	0	0	24.3	63.46	28.1	33.9
00-00	428	2	2	10	27	79	146	112	39	9	2	0	0	0	0	0	0	24.3	63.08	28.0	33.8

Peak step 17:00 (44) AM Peak step 8:00 (41) PM Peak step 17:00 (44)

*** Wednesday, September 18, 2024**

Time	Total	Vbin	Vbin	Vbin	Vbin	Vbin	Vbin	Vbin	Vbin	Vbin	Vbin	Vbin	Vbin	Vbin	Vbin	Vbin	Vbin	vPace	Pace%	Mean	Vpp
<--		0	5	10	15	20	25	30	35	40	45	50	55	60	65	70	75	10	10		85
		5	10	15	20	25	30	35	40	45	50	55	60	65	70	75	100				
0000	1	0	0	0	0	0	1	0	0	0	0	0	0	0	0	0	0	16.8	100.0	26.7	-
0100	2	0	0	0	0	0	2	0	0	0	0	0	0	0	0	0	0	18.9	100.0	28.2	-
0200	0	0	0	0	0	0	0	0	0	0	0	0	0	0	0	0	0	-	-	-	-
0300	0	0	0	0	0	0	0	0	0	0	0	0	0	0	0	0	0	-	-	-	-
0400	1	0	0	0	0	0	1	0	0	0	0	0	0	0	0	0	0	18.1	100.0	27.9	-
0500	5	0	0	0	1	2	1	1	0	0	0	0	0	0	0	0	0	17.0	80.00	24.1	-
0600	7	0	0	0	3	0	2	1	1	0	0	0	0	0	0	0	0	15.7	57.14	25.4	-
0700	12	0	0	1	2	2	5	1	1	0	0	0	0	0	0	0	0	20.5	66.67	24.1	30.6
0800	24	0	0	1	2	8	5	7	1	0	0	0	0	0	0	0	0	18.3	62.50	26.0	33.8
0900	21	0	0	0	3	3	6	6	2	1	0	0	0	0	0	0	0	24.2	57.14	27.9	35.6
1000	20	0	1	0	1	3	7	7	0	0	0	0	1	0	0	0	0	22.3	70.00	28.6	33.8
1100	17	0	0	1	1	4	5	3	3	0	0	0	0	0	0	0	0	21.6	58.82	28.0	36.6
1200	21	0	0	0	1	4	6	3	7	0	0	0	0	0	0	0	0	22.1	61.90	30.6	38.5
1300	28	0	0	1	1	5	13	6	2	0	0	0	0	0	0	0	0	20.9	67.86	27.3	32.9
1400	28	0	0	4	0	2	9	12	1	0	0	0	0	0	0	0	0	25.8	78.57	27.8	34.4
1500	27	0	1	0	3	3	11	8	1	0	0	0	0	0	0	0	0	23.3	70.37	26.8	32.8
1600	46	0	0	0	7	11	11	10	6	1	0	0	0	0	0	0	0	24.5	56.52	27.8	35.3
1700	34	0	0	2	1	9	12	7	1	2	0	0	0	0	0	0	0	21.3	70.59	27.3	32.9
1800	31	1	1	0	2	4	8	11	3	1	0	0	0	0	0	0	0	23.8	67.74	27.9	34.2
1900	25	0	0	3	1	8	4	8	0	1	0	0	0	0	0	0	0	22.0	64.00	26.3	32.8
2000	12	0	2	0	0	4	2	4	0	0	0	0	0	0	0	0	0	21.0	75.00	24.2	30.9
2100	12	0	0	0	2	3	4	3	0	0	0	0	0	0	0	0	0	22.8	83.33	25.9	31.3
2200	4	0	0	0	2	0	2	0	0	0	0	0	0	0	0	0	0	17.7	75.00	22.1	-
2300	3	0	0	0	0	0	3	0	0	0	0	0	0	0	0	0	0	18.6	100.0	26.5	-
07-19	309	1	3	10	24	58	98	81	28	5	0	0	1	0	0	0	0	24.2	59.55	27.6	34.1
06-22	365	1	5	13	30	73	110	97	29	6	0	0	1	0	0	0	0	24.2	59.73	27.3	33.8
06-00	372	1	5	13	32	73	115	97	29	6	0	0	1	0	0	0	0	24.2	59.95	27.2	33.7
00-00	381	1	5	13	33	75	120	98	29	6	0	0	1	0	0	0	0	22.8	60.10	27.2	33.6

Peak step 16:00 (46) AM Peak step 8:00 (24) PM Peak step 16:00 (46)

*** Thursday, September 19, 2024**

Time	Total	Vbin	Vbin	Vbin	Vbin	Vbin	Vbin	Vbin	Vbin	Vbin	Vbin	Vbin	Vbin	Vbin	Vbin	Vbin	Vbin	vPace	Pace%	Mean	Vpp
<--		0	5	10	15	20	25	30	35	40	45	50	55	60	65	70	75	10	10		85
		5	10	15	20	25	30	35	40	45	50	55	60	65	70	75	100				
0000	1	0	0	0	0	0	1	0	0	0	0	0	0	0	0	0	0	17.2	100.0	27.1	-
0100	2	0	0	0	0	0	1	1	0	0	0	0	0	0	0	0	0	22.3	100.0	29.3	-
0200	0	0	0	0	0	0	0	0	0	0	0	0	0	0	0	0	0	-	-	-	-
0300	0	0	0	0	0	0	0	0	0	0	0	0	0	0	0	0	0	-	-	-	-
0400	2	0	0	2	0	0	0	0	0	0	0	0	0	0	0	0	0	2.0	100.0	11.9	-
0500	4	0	0	0	1	1	2	0	0	0	0	0	0	0	0	0	0	19.5	75.00	24.6	-
0600	4	0	0	0	1	1	1	1	0	0	0	0	0	0	0	0	0	13.6	50.00	25.8	-
0700	9	0	0	0	0	3	4	2	0	0	0	0	0	0	0	0	0	20.5	88.89	26.7	-
0800	23	0	0	0	2	7	8	6	0	0	0	0	0	0	0	0	0	22.0	78.26	26.3	31.4
0900	24	1	0	1	2	4	5	9	1	1	0	0	0	0	0	0	0	23.3	62.50	27.1	33.2
1000	16	0	0	1	0	3	7	4	1	0	0	0	0	0	0	0	0	23.5	75.00	27.3	33.1
1100	21	0	0	2	2	5	6	4	1	1	0	0	0	0	0	0	0	21.6	66.67	25.9	31.4
1200	28	0	0	0	2	4	13	2	7	0	0	0	0	0	0	0	0	19.9	60.71	28.9	37.4
1300	35	0	0	2	2	10	14	5	2	0	0	0	0	0	0	0	0	20.8	74.29	25.7	30.6
1400	31	0	0	2	2	4	14	8	0	1	0	0	0	0	0	0	0	22.7	74.19	27.1	32.6
1500	31	0	0	0	2	6	11	8	2	2	0	0	0	0	0	0	0	23.2	67.74	28.7	34.7
1600	33	0	0	0	0	2	16	8	6	1	0	0	0	0	0	0	0	25.6	78.79	30.5	36.1
1700	30	0	0	2	4	3	14	5	1	1	0	0	0	0	0	0	0	22.1	63.33	26.5	32.3
1800	35	0	0	0	2	8	14	8	3	0	0	0	0	0	0	0	0	20.4	65.71	27.6	33.5
1900	25	0	0	1	4	6	9	3	1	1	0	0	0	0	0	0	0	18.7	60.00	25.6	32.0
2000	16	0	0	1	1	3	5	5	0	1	0	0	0	0	0	0	0	22.6	62.50	26.9	33.0
2100	7	0	0	0	0	0	5	2	0	0	0	0	0	0	0	0	0	22.4	100.0	28.2	-
2200	3	0	0	0	0	1	2	0	0	0	0	0	0	0	0	0	0	19.6	100.0	25.3	-
2300	2	0	0	0	0	0	2	0	0	0	0	0	0	0	0	0	0	23.5	100.0	31.7	-
07-19	316	1	0	10	20	59	126	69	24	7	0	0	0	0	0	0	0	23.2	64.56	27.5	33.0
06-22	368	1	0	12	26	69	146	80	25	9	0	0	0	0	0	0	0	23.2	63.86	27.3	33.0
06-00	373	1	0	12	26	70	148	82	25	9	0	0	0	0	0	0	0	23.2	63.81	27.3	33.0
00-00	382	1	0	14	27	71	152	83	25	9	0	0	0	0	0	0	0	23.2	63.61	27.2	33.0

Peak step 13:00 (35) AM Peak step 9:00 (24) PM Peak step 13:00 (35)

*** Grand Total**

Time	Total	Vbin	Vbin	Vbin	Vbin	Vbin	Vbin	Vbin	Vbin	Vbin	Vbin	Vbin	Vbin	Vbin	Vbin	Vbin	Vbin	vPace	Pace%	Mean	Vpp
<--		0	5	10	15	20	25	30	35	40	45	50	55	60	65	70	75	10	10		85
--		5	10	15	20	25	30	35	40	45	50	55	60	65	70	75	100				
--	1191	4	7	37	87	225	418	293	93	24	2	0	1	0	0	0	0	24.3	62.05	27.5	33.4

Traffic Data Service -- San Jose, CA Speed Report

CustomList-2497 -- English (ENU)

Datasets:

Site: [3] LOS OLIVOS DR BT JOHNSON PL AND AUSTIN PL
Data type: Axle sensors - Paired (Class/Speed/Count)

Profile:

Included classes: 1, 2, 3, 4, 5, 6, 7, 8, 9, 10, 11, 12, 13
Speed range: 0 - 100 mph.
Direction: South (bound), P = North, Lane = 0-16
Name: Default Profile
Scheme: Vehicle classification (Scheme F)
Units: Non metric (ft, mi, ft/s, mph, lb, ton)

Column Legend:

- 0 [Time]** 24-hour time (0000 - 2359)
- 1 [Total]** Number in time step
- 2 [Vbin]** Speed bin totals
- 3 [vPace]** Speed at start of pace
- 4 [Pace%]** Percent in pace
- 5 [Mean]** Average speed
- 6 [Vpp]** Percentile speed

*** Tuesday, September 17, 2024**

Time	Total	Vbin	Vbin	Vbin	Vbin	Vbin	Vbin	Vbin	Vbin	Vbin	Vbin	Vbin	Vbin	Vbin	Vbin	Vbin	Vbin	vPace	Pace%	Mean	Vpp
<--		0	5	10	15	20	25	30	35	40	45	50	55	60	65	70	75	10	10		85
		5	10	15	20	25	30	35	40	45	50	55	60	65	70	75	100				
0000	4	0	0	0	2	1	0	1	0	0	0	0	0	0	0	0	0	12.0	75.00	22.3	-
0100	1	0	0	0	0	0	0	1	0	0	0	0	0	0	0	0	0	24.2	100.0	34.0	-
0200	0	0	0	0	0	0	0	0	0	0	0	0	0	0	0	0	0	-	-	-	-
0300	3	0	0	0	1	1	0	1	0	0	0	0	0	0	0	0	0	19.3	66.67	30.2	-
0400	0	0	0	0	0	0	0	0	0	0	0	0	0	0	0	0	0	-	-	-	-
0500	4	0	0	0	0	1	0	2	1	0	0	0	0	0	0	0	0	30.6	75.00	34.9	-
0600	4	0	0	0	3	0	0	1	0	0	0	0	0	0	0	0	0	8.3	75.00	20.9	-
0700	41	0	0	1	4	9	10	15	1	1	0	0	0	0	0	0	0	23.8	65.85	27.5	33.1
0800	60	0	0	4	10	24	16	5	1	0	0	0	0	0	0	0	0	23.8	66.67	28.4	33.4
0900	39	0	0	2	0	9	14	12	2	0	0	0	0	0	0	0	0	22.6	71.79	27.7	33.2
1000	23	0	0	1	1	4	11	6	0	0	0	0	0	0	0	0	0	21.7	78.26	26.5	31.1
1100	31	1	0	1	2	8	6	7	5	1	0	0	0	0	0	0	0	21.9	51.61	27.8	36.1
1200	28	0	0	0	4	3	8	11	1	1	0	0	0	0	0	0	0	24.7	67.86	28.1	33.5
1300	33	0	0	1	5	6	12	6	3	0	0	0	0	0	0	0	0	24.3	60.61	27.0	34.1
1400	34	0	0	2	4	5	7	13	2	1	0	0	0	0	0	0	0	24.6	58.82	27.6	34.4
1500	49	0	0	2	3	11	14	13	5	0	1	0	0	0	0	0	0	22.0	65.31	27.8	33.7
1600	56	0	0	0	2	14	17	15	6	2	0	0	0	0	0	0	0	23.5	64.29	28.7	35.0
1700	60	0	0	1	2	9	22	18	8	0	0	0	0	0	0	0	0	22.7	70.00	29.0	34.5
1800	67	0	1	2	3	15	29	16	1	0	0	0	0	0	0	0	0	22.1	77.61	27.1	31.8
1900	41	0	0	0	3	9	16	9	3	0	0	1	0	0	0	0	0	22.9	63.41	28.4	34.2
2000	33	1	1	1	0	10	10	9	1	0	0	0	0	0	0	0	0	22.3	72.73	26.0	33.3
2100	17	0	0	0	2	5	5	3	2	0	0	0	0	0	0	0	0	21.4	64.71	27.0	33.9
2200	6	0	0	1	2	1	1	0	1	0	0	0	0	0	0	0	0	10.4	66.67	21.9	-
2300	0	0	0	0	0	0	0	0	0	0	0	0	0	0	0	0	0	-	-	-	-
07-19	521	1	1	13	34	103	174	148	39	7	1	0	0	0	0	0	0	24.0	63.92	27.9	33.7
06-22	616	2	2	14	42	127	205	170	45	7	1	1	0	0	0	0	0	23.6	63.31	27.7	33.5
06-00	622	2	2	15	44	128	206	170	46	7	1	1	0	0	0	0	0	23.6	62.86	27.7	33.6
00-00	634	2	2	15	46	130	208	172	49	8	1	1	0	0	0	0	0	23.6	62.30	27.7	33.7

Peak step 18:00 (67) AM Peak step 8:00 (60) PM Peak step 18:00 (67)

*** Wednesday, September 18, 2024**

Time	Total	Vbin	Vbin	Vbin	Vbin	Vbin	Vbin	Vbin	Vbin	Vbin	Vbin	Vbin	Vbin	Vbin	Vbin	Vbin	Vbin	vPace	Pace%	Mean	Vpp
<--		0	5	10	15	20	25	30	35	40	45	50	55	60	65	70	75	10	10		85
		5	10	15	20	25	30	35	40	45	50	55	60	65	70	75	100				
0000	2	0	0	1	1	0	0	0	0	0	0	0	0	0	0	0	0	7.9	100.0	14.8	-
0100	1	0	0	0	0	0	0	1	0	0	0	0	0	0	0	0	0	16.1	100.0	25.9	-
0200	1	0	0	0	0	0	0	1	0	0	0	0	0	0	0	0	0	16.6	100.0	26.4	-
0300	1	0	0	0	0	0	0	1	0	0	0	0	0	0	0	0	0	19.5	100.0	29.3	-
0400	4	0	0	0	0	0	4	0	0	0	0	0	0	0	0	0	0	20.1	100.0	27.5	-
0500	3	0	0	0	0	0	0	1	2	0	0	0	0	0	0	0	0	27.3	100.0	35.4	-
0600	7	0	0	0	2	1	1	3	0	0	0	0	0	0	0	0	0	21.6	71.43	25.4	-
0700	35	0	0	1	2	8	14	7	2	1	0	0	0	0	0	0	0	22.4	68.57	27.3	33.6
0800	50	0	0	0	0	12	22	11	5	0	0	0	0	0	0	0	0	20.6	74.00	28.4	33.7
0900	32	0	0	1	2	8	15	5	1	0	0	0	0	0	0	0	0	20.1	71.88	26.3	31.5
1000	34	0	0	0	2	7	14	9	2	0	0	0	0	0	0	0	0	21.6	79.41	27.6	31.6
1100	32	1	0	0	0	9	15	7	0	0	0	0	0	0	0	0	0	23.6	78.13	26.3	31.2
1200	33	0	0	2	3	10	9	6	3	0	0	0	0	0	0	0	0	18.2	57.58	25.9	34.2
1300	37	0	0	0	3	7	13	11	3	0	0	0	0	0	0	0	0	23.8	78.38	27.9	32.6
1400	51	1	0	1	4	13	22	8	1	1	0	0	0	0	0	0	0	21.1	72.55	26.2	31.2
1500	46	0	0	0	2	8	15	16	3	2	0	0	0	0	0	0	0	24.9	69.57	29.3	34.2
1600	66	0	0	3	4	9	31	15	3	1	0	0	0	0	0	0	0	22.3	80.30	27.4	31.5
1700	65	0	1	1	10	13	26	11	2	1	0	0	0	0	0	0	0	21.3	64.62	25.9	31.1
1800	61	0	0	2	4	13	29	10	3	0	0	0	0	0	0	0	0	20.2	72.13	26.4	31.0
1900	36	0	0	0	3	10	10	10	2	1	0	0	0	0	0	0	0	22.9	63.89	27.5	32.8
2000	29	0	0	0	2	11	12	4	0	0	0	0	0	0	0	0	0	18.2	79.31	25.3	29.1
2100	19	0	0	0	1	6	6	6	0	0	0	0	0	0	0	0	0	20.6	78.95	26.9	30.9
2200	7	0	0	0	0	5	1	1	0	0	0	0	0	0	0	0	0	20.6	100.0	24.2	-
2300	1	0	0	0	0	0	0	1	0	0	0	0	0	0	0	0	0	20.5	100.0	30.3	-
07-19	542	2	1	11	36	117	225	116	28	6	0	0	0	0	0	0	0	21.8	68.63	27.1	32.1
06-22	633	2	1	11	44	145	254	139	30	7	0	0	0	0	0	0	0	22.3	68.40	27.0	32.1
06-00	641	2	1	11	44	150	255	141	30	7	0	0	0	0	0	0	0	22.3	68.33	27.0	32.1
00-00	653	2	1	12	45	150	262	142	32	7	0	0	0	0	0	0	0	22.3	68.15	27.0	32.1

Peak step 16:00 (66) AM Peak step 8:00 (50) PM Peak step 16:00 (66)

*** Thursday, September 19, 2024**

Time	Total	Vbin	Vbin	Vbin	Vbin	Vbin	Vbin	Vbin	Vbin	Vbin	Vbin	Vbin	Vbin	Vbin	Vbin	Vbin	Vbin	vPace	Pace%	Mean	Vpp
<--		0	5	10	15	20	25	30	35	40	45	50	55	60	65	70	75	10	10		85
		5	10	15	20	25	30	35	40	45	50	55	60	65	70	75	100				
0000	1	0	0	0	0	0	1	0	0	0	0	0	0	0	0	0	0	18.1	100.0	28.0	-
0100	2	0	0	0	0	0	2	0	0	0	0	0	0	0	0	0	0	16.7	100.0	25.9	-
0200	0	0	0	0	0	0	0	0	0	0	0	0	0	0	0	0	0	-	-	-	-
0300	3	0	0	0	1	1	1	0	0	0	0	0	0	0	0	0	0	12.6	66.67	21.3	-
0400	2	0	0	0	0	1	0	0	1	0	0	0	0	0	0	0	0	14.3	50.00	31.1	-
0500	6	0	0	0	1	1	0	1	3	0	0	0	0	0	0	0	0	26.5	66.67	30.5	-
0600	8	0	0	0	3	2	2	1	0	0	0	0	0	0	0	0	0	14.1	62.50	23.2	-
0700	35	0	0	1	5	9	11	6	3	0	0	0	0	0	0	0	0	20.9	60.00	26.3	33.4
0800	56	0	0	1	4	13	23	12	3	0	0	0	0	0	0	0	0	20.9	75.00	26.9	31.0
0900	39	0	1	4	2	10	16	4	2	0	0	0	0	0	0	0	0	19.9	66.67	24.3	30.1
1000	30	0	0	0	2	7	12	6	3	0	0	0	0	0	0	0	0	22.0	73.33	27.5	32.4
1100	36	0	1	3	3	12	7	9	1	0	0	0	0	0	0	0	0	21.3	69.44	25.0	31.0
1200	30	0	0	0	1	9	11	7	1	1	0	0	0	0	0	0	0	23.8	76.67	27.7	33.2
1300	36	0	1	0	4	10	18	2	1	0	0	0	0	0	0	0	0	19.8	80.56	25.5	29.6
1400	43	0	0	0	5	7	20	7	4	0	0	0	0	0	0	0	0	21.6	67.44	27.2	33.1
1500	50	0	0	1	4	4	20	18	1	2	0	0	0	0	0	0	0	24.8	76.00	28.5	33.6
1600	50	0	0	0	1	9	18	14	7	1	0	0	0	0	0	0	0	22.4	72.00	29.2	35.2
1700	60	0	1	2	7	10	18	15	6	1	0	0	0	0	0	0	0	23.3	58.33	27.1	33.8
1800	45	0	0	1	5	13	14	11	1	0	0	0	0	0	0	0	0	22.0	71.11	26.2	31.9
1900	50	0	0	3	6	7	27	5	2	0	0	0	0	0	0	0	0	19.9	68.00	25.6	30.2
2000	29	0	0	0	0	5	17	5	2	0	0	0	0	0	0	0	0	24.2	86.21	28.1	33.7
2100	13	0	0	1	2	3	5	1	1	0	0	0	0	0	0	0	0	17.0	61.54	24.5	31.4
2200	3	0	0	0	0	3	0	0	0	0	0	0	0	0	0	0	0	13.9	100.0	23.0	-
2300	4	0	0	0	0	1	2	1	0	0	0	0	0	0	0	0	0	21.0	100.0	27.4	-
07-19	510	0	4	13	43	113	188	111	33	5	0	0	0	0	0	0	0	22.3	65.10	26.9	32.4
06-22	610	0	4	17	54	130	239	123	38	5	0	0	0	0	0	0	0	22.3	65.57	26.7	32.2
06-00	617	0	4	17	54	134	241	124	38	5	0	0	0	0	0	0	0	22.3	65.80	26.7	32.2
00-00	631	0	4	17	56	137	245	125	42	5	0	0	0	0	0	0	0	22.3	65.61	26.7	32.2

Peak step 17:00 (60) AM Peak step 8:00 (56) PM Peak step 17:00 (60)

*** Grand Total**

Time	Total	Vbin	Vbin	Vbin	Vbin	Vbin	Vbin	Vbin	Vbin	Vbin	Vbin	Vbin	Vbin	Vbin	Vbin	Vbin	Vbin	vPace	Pace%	Mean	Vpp
<--		0	5	10	15	20	25	30	35	40	45	50	55	60	65	70	75	10	10		85
--		5	10	15	20	25	30	35	40	45	50	55	60	65	70	75	100				
--	1918	4	7	44	147	417	715	439	123	20	1	1	0	0	0	0	0	22.3	65.07	27.1	32.8