

EXPANSION JOINT

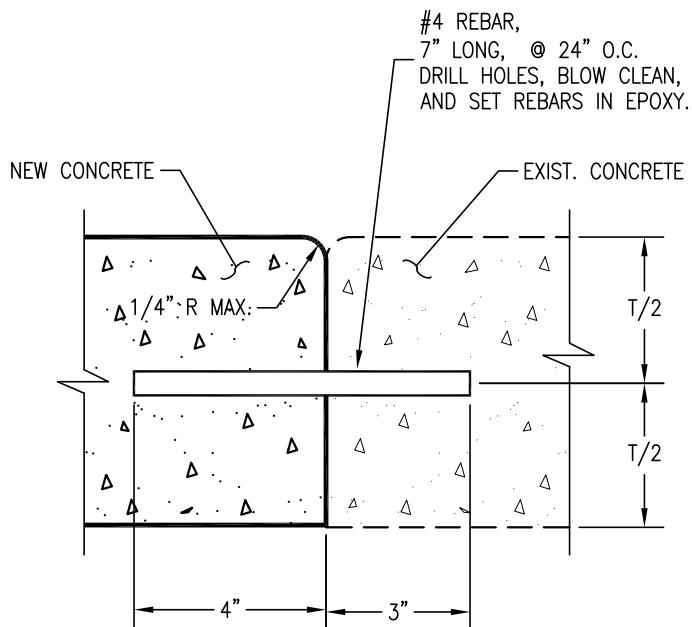

SIDEWALK CONTACT JOINT
"COLD JOINT"

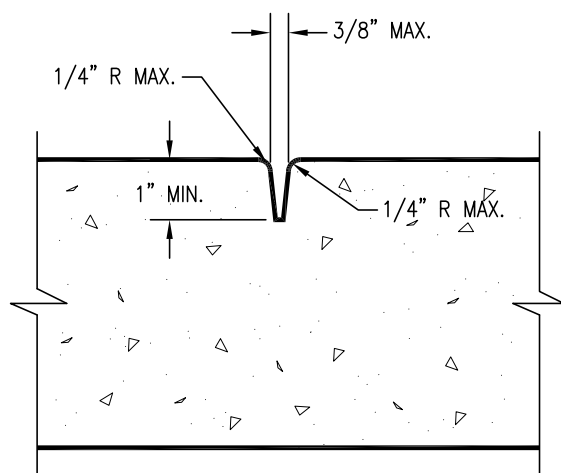

WEAKENED PLANE JOINT
"DEEP JOINT"

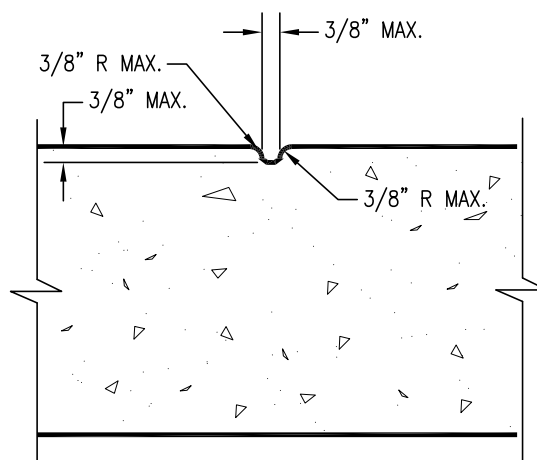

SCORE MARK
"DUMMY JOINT"



DRAWN BY: K. TRAN

CHECKED BY: F. AMIN

APPROVED BY: G. GOMEZ

DATE: OCTOBER 2013

CONCRETE JOINTS

CITY OF SANTA CLARA

ST-17

PAGE: 17